

Dvojitá vsuvka

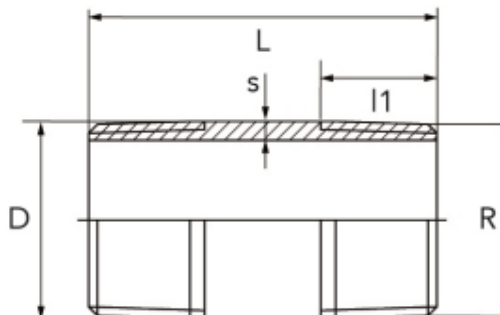

Technický list výrobku

Rozmer	L	I1	D	s	kg
1/8"	40	8	10,2	2,00	0,017
1/4"	40	11	13,5	2,35	0,020
3/8"	40	12	17,2	2,35	0,028
1/2"	60	15	21,3	2,65	0,060
3/4"	60	17	26,9	2,65	0,072
1"	60	20	33,7	3,25	0,113
5/4"	80	22	42,4	3,25	0,198
6/4"	80	22	48,3	3,25	0,230
2"	100	26	60,3	3,65	0,460
2 1/2"	100	28	76,1	3,65	0,528
3"	120	35	88,9	4,05	0,860
4"	150	42	114,3	4,00	1,340

Akost: 1.4404